

the latest generation
NC Cooling Tower



Company Confidential

GLOBAL INFRASTRUCTURE X PROCESS EQUIPMENT X DIAGNOSTIC TOOLS



Features and Benefits

- > Performance
- > Design
- > Components
- > Connections
- > Access and Safety
- > Accessories



Performance

- > **Highest single unit capacity in the world**
 - 101 – 1439 tons
- > **All models meet ASHRAE 90.1 Standard**
- > **Best in class**
 - Performance per cell
 - Tons/hp
 - Tons/plan area
- > **Constructed from up to 71% recycled content**



**COOL IS
GREEN
IS COOL**



Design

- > Crossflow
- > Induced draft
- > Vertical discharge



Design

> Global Certifications and Codes

- CTI
- ASHRAE 90.1
- ASCE
- OSHA
- ACOP L8
- IBC
- FM
- China GB7
- Eurovent
- ISO
- BS



Design

> Factory Assembled Modular Construction

- Four point support allows parallel I-beams in any direction
- Simplified installation



Design

> Durable construction

- G-235 galvanized
- Series 300 stainless steel *option*
- 316 stainless steel *option*
- Recyclable at the end of the product's life
- Some coatings provided by others:
 - Not FM approved
 - Non-recyclable
- FM available on all models



Design

> Seismic and wind loading

- Zone 2B seismic design standard
- Level 1 (30 psf minimum) design standard



Components

> Suspended film fill

- MX75 PVC film fill
- More heat transfer surface = greater efficiency

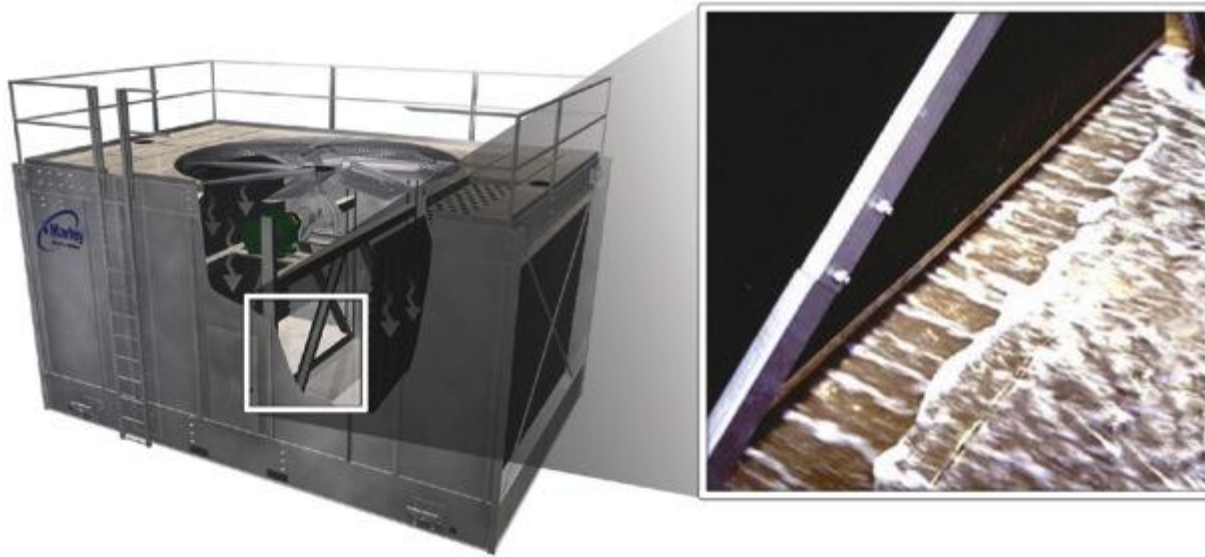

Components

> Integral louvers and drift eliminators

- As low as .001% drift rates
- Reduces splash-out, icing and saves water
- Lower pressure drop
- High temp *option* up to 140°F

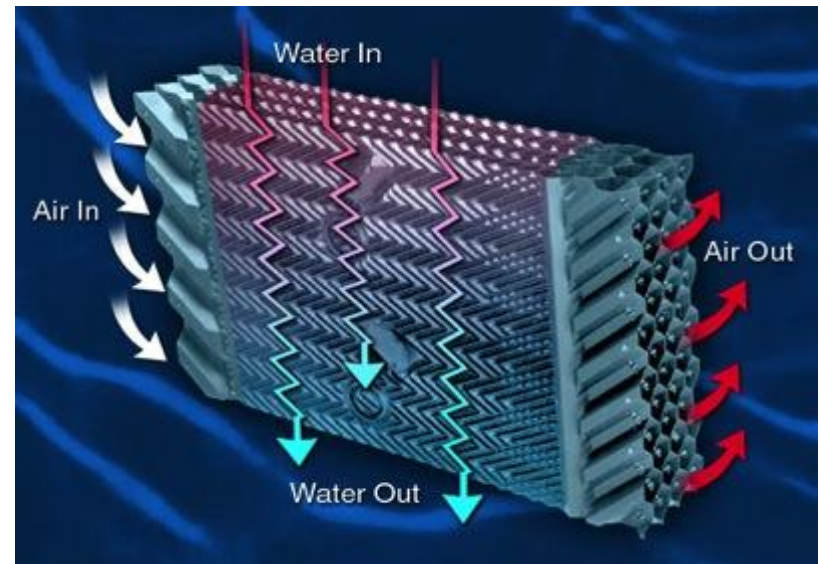

Components

> System 5 Geareducer and drive

- Quiet
- Energy efficient
- 5 year service interval
 - Low maintenance
- 5 year warranty
- Belt drive *option* (up to 60hp)

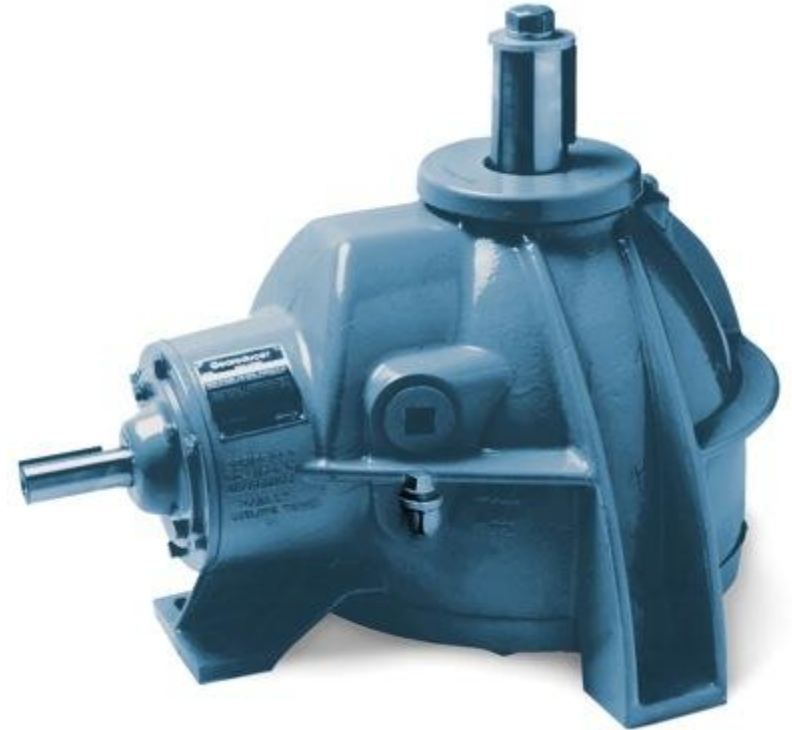

Components

- > **High-efficiency axial fan**
 - Low sound fan *standard*
 - Adjustable pitch



Components

- > **TEFC horizontal-shaft motor**
 - Fan cooled for extended life
 - Reduced sound
 - 5 year warranty on NEMA premium
 - Designed for cooling tower duty



Components

> External motor option

- Located outside the fan plenum area
- Easy maintenance and replacement



Components

> 5 year mechanical warranty

- Fan
- Geareducer
- Coupling
- Support beams



Connections

> HC Balancing Valves

- Conventional outside piping for balancing water to the distribution basins

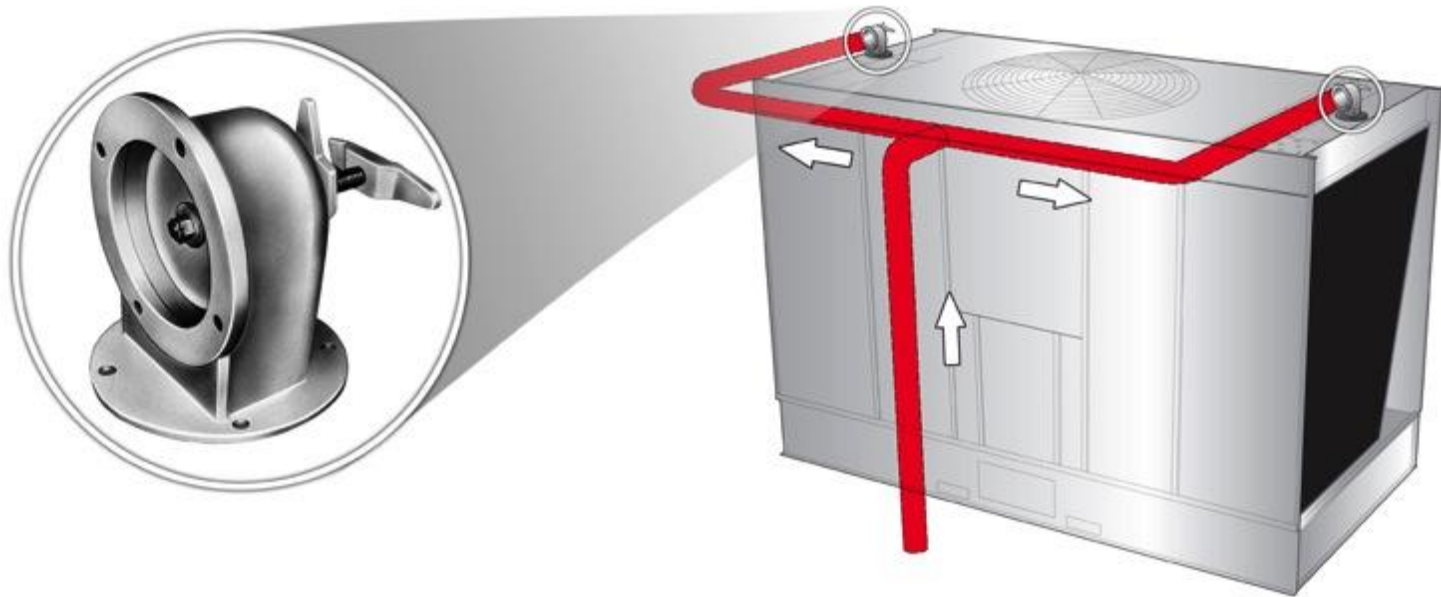

Connections

> System connect single side inlet

- Simple
- Quick
- Cost Effective

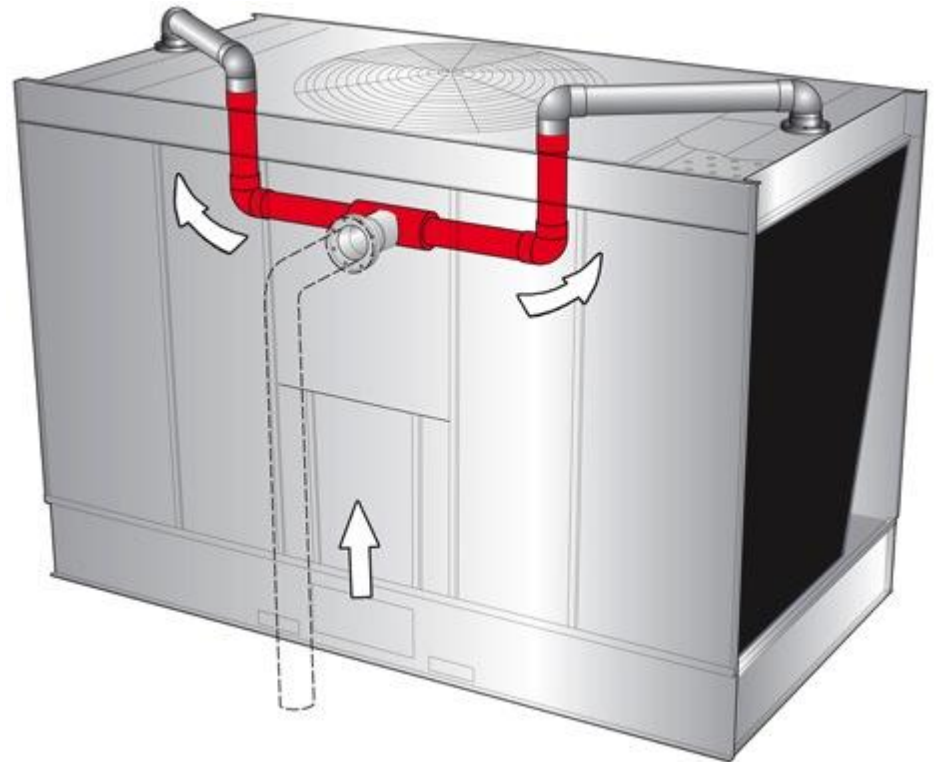

Connections

> System connect single bottom inlet

- Provide all internal piping
- Ease of installation

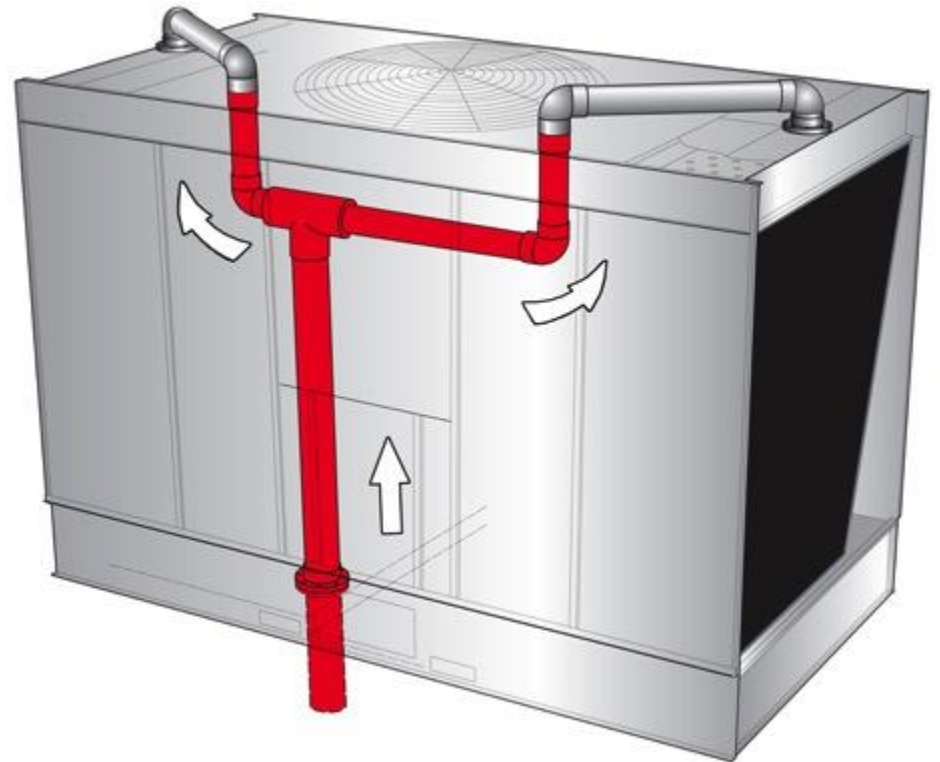

Connections

> Water outlet options

- Cased face suction
- Bottom outlet
- Sump outlet

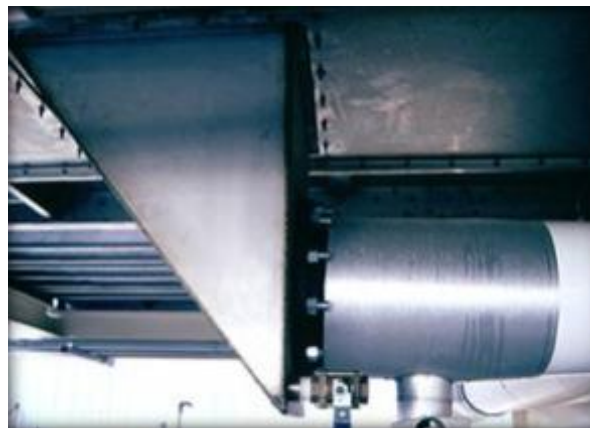

Connections

- > **Sloped water collection basin**
 1. Basin slopes for easy cleaning
 2. Float operated make-up valve
 - Water level probe available
 3. Outflows of any type are located in the depressed area of the cold water basin

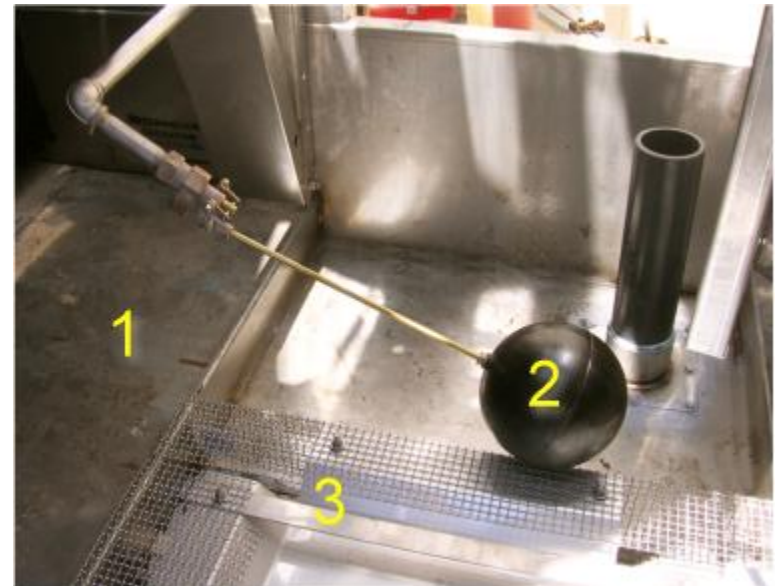

Access and Safety

- > **Largest access doors on the market!**
 - Access doors are hinged and latched
 - Spacious plenum between fill banks for access to tower interior



Access and Safety

> Ladder, Handrail and Safety Cage Options

- Welded components
- Easy fit options for quick installation
- Fan deck and basin covers are a walking surface



Access and Safety

- > **Platforms and Ladder Extension Options**
 - Ease of maintenance to the tower



Access and Safety

> Field installation hours

	NC8305	NC8405
Set Tower	4	4
Guardrails	3	2
Safety Cage	4+	0.25
Fan Cylinder	1	0
Platform Assembly	7	5
Factory installed terminal box	16	4
Total	35	15.25

56% Reduction Possible!

Accessories

> Low Sound Options

- Low sound fan is standard
- Inlet and/or outlet attenuation
- Quiet or Ultra-Quiet fans



Accessories

> Two speed motors

- Valuable for environments where wet-bulb temp varies
- More energy efficient than single speed motors

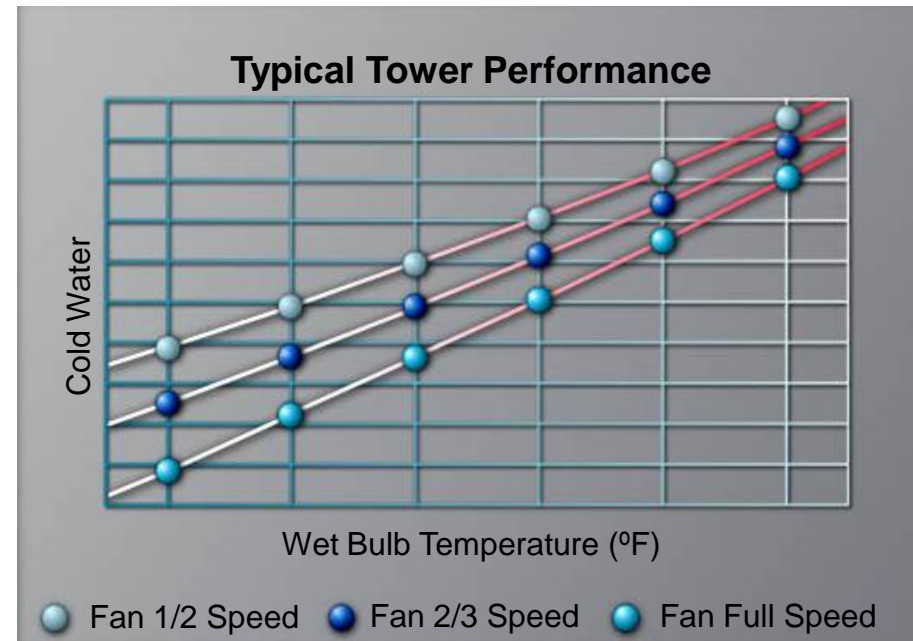

Accessories

> Variable Speed Drive

- Increases control and energy savings
- More precise temperature control



Accessories

> Controls

- Maximize energy management
- Combines multiple control options into one cabinet
- Factory mounted terminal box



Marley is Raising the Industry Bar – Again.

- > Highest capacity
- > Highest efficiency
- > Smaller profile
- > More applications
- > Marley reliability



